



21111008
Anemos
Scroll Vacuum Pump
User Manual

Table of Contents	
I. Disclaimer & Warranty.....	3
LIMITED WARRANTY & DISCLAIMER.....	3
LIMITATION OF LIABILITY.....	5
II. Safety.....	7
2.1 After Sales Support.....	9
III. Anemos Oil-free Scroll Vacuum Pump.....	10
3.1 Introduction.....	10
3.2 Precautions.....	11
IV. Technical Specifications.....	12
4.1 Specifications.....	12
4.2 Dimensions.....	13
V. Installation and Operation.....	14
5.1 Operation environment requirement.....	14
5.2 Electrical Connection.....	14
5.3 Operation.....	15
VI. Interface.....	16
6.1 Pin definition.....	16
VII. Inspection.....	17
The package includes the following items.....	17
VIII. Maintenance.....	18
IX. Troubleshooting.....	19

I. Disclaimer & Warranty

- The intellectual property rights for this manual belongs to Holland Green Science Corporation (hereinafter referred to as “the Company”).
- Products of the company are under the patent protection of China and other countries and regions (inclusive of obtained patents and patents currently under application).
- The company reserves the right to change product specifications without notice.
- The contents of the manual are subject to change without notice.-The manual’s content must not be copied, extracted, or modified in any form without the Company’s permission.

LIMITED WARRANTY & DISCLAIMER

Products sold by the Company are intended solely for the use(s) specified by the manufacturer and are not to be used for any other purposes including, but not limited to, unauthorized commercial purposes. Buyer warrants and represents that Buyer will properly test, use, qualify, and/or validate each Product for intended use, and, to the extent authorized, manufacture and market any final articles made from the Company’s Products in accordance with the practices of a reasonable person who is an expert in the field, and in strict compliance with all applicable national, state and local laws and regulations. Buyer acknowledges and understands that the purchase of Products only conveys to Buyer the non-transferable right for only the Buyer to use the Products purchased in compliance with the applicable manufacturer’s Published User Statement, Limited User Statement, or Limited License, if any. While this manual contains certain representations of the potential dangers from the instrument or equipment, Buyer is solely responsible for conducting any research necessary to learn the hazards involved for any of its intended uses of the instrument or equipment purchased from the Company and to properly warn its customers, employees and other personnel who may be exposed to such instrument or equipment of any risks involved in using or handling the instrument or equipment.

The Company warrants that this product will operate or perform substantially in conformance with the Company’s published specifications and be free from defects in material and workmanship, when subjected to normal, proper and intended storage and usage by properly trained personnel, for the duration of the manufacturer’s warranty period set forth in this product documentation, published specifications or package inserts. If a manufacturer’s warranty period is not specified in the product documentation, published specifications or package inserts, the warranty period shall be one (1) year from the date of Bill of Sale to Buyer for equipment, and the earlier of any stated expiration dates or ninety (90) days for all other products (the “Warranty Period”). The Company agrees during the Warranty Period, to repair or replace, at the Company’s option, defective Products so as to cause the same to operate in substantial conformance with said published specifications; provided that Buyer shall (a) promptly notify the Company in writing upon the discovery of any defect, which notice shall include the product model and serial number (if applicable) and details of the warranty claim; and (b) after the Company’s review, the Company will provide Buyer with service data and/or a Return Material Authorization (“RMA”), which may include biohazard decontamination procedures and other product-

specific handling instructions, then, if applicable, Buyer may return the defective Products to the Company with all costs prepaid by Buyer. Replacement parts may be new or refurbished, at the election of the Company. All replaced parts shall become the property of the Company. Shipment to Buyer of repaired or replacement Products shall be made in accordance with the Delivery provisions of the Terms & Conditions agreed to by the purchase of this product. Consumables are expressly excluded from this warranty.

Notwithstanding the foregoing, Products supplied by the Company but not manufactured by the Company are not warranted by the Company, and the Company disclaims all warranties associated with the accuracy of any original manufacturer or third-party supplier Product information, but the Company agrees to assign to Buyer any warranty rights in such Product that the Company may have from the original manufacturer or third-party supplier, to the extent such assignment is allowed by such original manufacturer or third-party supplier.

In no event shall the Company have any obligation to make repairs, replacements or corrections required, in whole or in part, as the result of (i) normal wear and tear, (ii) accident, disaster or event of force majeure, (iii) misuse, fault or negligence of or by Buyer, (iv) use of the Product in a manner for which they were not designed, (v) causes external to the Product such as, but not limited to, power failure or electrical power surges, (vi) improper storage and handling of the Product or (vii) use of the Product in combination with equipment or software not supplied by the Company. If the Company determines that Product for which Buyer has requested warranty services are not covered by the warranty hereunder, Buyer shall pay or reimburse the Company for all costs of investigating and responding to such request at the Company's then prevailing time and materials rates. If the Company provides repair services or replacement parts that are not covered by this warranty, Buyer shall pay the Company therefor at the Company's then prevailing time and materials rates.

ANY INSTALLATION, MAINTENANCE, REPAIR, SERVICE, RELOCATION OR ALTERATION TO OR OF, OR OTHER TAMPERING WITH, THE PRODUCT PERFORMED BY ANY PERSON OR ENTITY OTHER THAN THE COMPANY WITHOUT THE COMPANY'S PRIOR WRITTEN APPROVAL, OR ANY USE OF REPLACEMENT PARTS NOT SUPPLIED BY THE COMPANY, SHALL IMMEDIATELY VOID AND CANCEL ALL WARRANTIES WITH RESPECT TO THE PRODUCT.

THE OBLIGATIONS CREATED BY THIS WARRANTY STATEMENT TO REPAIR OR REPLACE A DEFECTIVE PRODUCT SHALL BE THE SOLE REMEDY OF BUYER IN THE EVENT OF A DEFECTIVE PRODUCT. EXCEPT AS EXPRESSLY PROVIDED IN THIS WARRANTY STATEMENT, THE COMPANY DISCLAIMS ALL OTHER WARRANTIES, WHETHER EXPRESS OR IMPLIED, ORAL OR WRITTEN, WITH RESPECT TO THE PRODUCTS, INCLUDING WITHOUT LIMITATION ALL IMPLIED WARRANTIES OF MERCHANTABILITY OR FITNESS FOR ANY PARTICULAR PURPOSE OR USE. THE COMPANY DOES NOT WARRANT THAT THE PRODUCTS ARE ERROR-FREE OR WILL ACCOMPLISH ANY PARTICULAR RESULT.

NOTHING IN THIS MANUAL OR IN THE TERMS AND AGREEMENT AGREED TO AT THE TIME OF PURCHASE SHALL BE CONSTRUED TO PROVIDE FOR THE TRANSFER, ASSIGNMENT OR ALIENATION OF THE LIMITED WARRANTIES PROVIDED BY THE COMPANY HEREIN TO ANY OTHER PARTY OTHER THAN BUYER, INCLUDING BUT NOT LIMITED TO, SUCCESSORS, HEIRS, SUBSIDIARIES OR ANY OTHER THIRD PERSON.

THE WARRANTIES IDENTIFIED ABOVE ARE THE SOLE AND EXCLUSIVE WARRANTIES WITH RESPECT TO THIS PRODUCT AND ARE IN LIEU OF ALL OTHER WARRANTIES, EXPRESS OR IMPLIED. ALL OTHER WARRANTIES ARE EXPRESSLY DISCLAIMED, INCLUDING, WITHOUT LIMITATION, THOSE OF NON-INFRINGEMENT, MERCHANTABILITY, OR FITNESS FOR A SPECIFIC PURPOSE OR USE (WHETHER ARISING FROM STATUTE, OR OTHERWISE IN LAW, OR FROM A COURSE OF DEALING, OR USAGE OF TRADE). THIS WARRANTY IS **NOT** TRANSFERABLE FROM THE ORIGINAL PURCHASER TO A SUBSEQUENT OWNER. FURTHER, THE COMPANY IS NOT LIABLE IN CASES OF DELIBERATE, NEGLIGENT OR ACCIDENTAL MISUSE OF THE PRODUCTS, USE WITH INAPPROPRIATE REAGENTS OR CONSUMABLES, DAMAGE CAUSED BY DISASTER, REPAIR OR MODIFICATIONS DONE BY ANYONE OTHER THAN THE COMPANY. THE COMPANY DOES NOT WARRANT THAT THE PRODUCT WILL NOT INFRINGE THE INTELLECTUAL PROPERTY RIGHTS OF A THIRD PARTY EITHER ALONE OR IN COMBINATION WITH OTHER PRODUCTS OR IN THE OPERATION OF ANY PROCESS. THE COMPANY'S TOTAL LIABILITY FOR BREACH OF THESE WARRANTIES SHALL BE LIMITED TO THE GROSS PURCHASE PRICE FOR THE PRODUCT AS STATED IN THE RELEVANT INVOICE OR ORDER UNDER WHICH THE ACTIVITY GIVING RISE TO LIABILITY ARISES. UNDER NO CIRCUMSTANCES SHALL THE COMPANY BE LIABLE FOR INDIRECT, INCIDENTAL, CONSEQUENTIAL, SPECIAL OR PUNITIVE DAMAGES (INCLUDING LOSS OF BUSINESS OR PROFITS) UNDER ANY THEORY OF LIABILITY HEREUNDER.

For claims under the warranty please contact your local supplier. You may also send the instrument directly to manufacturer, enclosing the invoice copy and by giving reasons for the claim.

LIMITATION OF LIABILITY

NOTWITHSTANDING ANYTHING TO THE CONTRARY CONTAINED HEREIN, THE LIABILITY OF THE COMPANY UNDER THESE TERMS AND CONDITIONS (WHETHER BY REASON OF BREACH OF CONTRACT, TORT, INDEMNIFICATION, OR OTHERWISE, BUT EXCLUDING LIABILITY OF THE COMPANY FOR BREACH OF WARRANTY (THE SOLE REMEDY FOR WHICH SHALL BE AS PROVIDED UNDER THIS SECTION) SHALL NOT EXCEED AN AMOUNT EQUAL TO THE LESSER OF (A) THE TOTAL PURCHASE PRICE THERETOFORE PAID BY BUYER TO THE COMPANY WITH RESPECT TO THE PRODUCT(S) GIVING RISE TO SUCH LIABILITY OR (B) ONE HUNDRED THOUSAND DOLLARS (\$100,000), WHICHEVER IS LESS.

With respect to any software products incorporated in or forming a part of the Product hereunder Buyer intends and agrees that such software products are being licensed and not sold, and that the words "purchase", "sell" or similar or derivative words are understood and agreed to mean "license", and that the word "Buyer" or similar or derivative words are understood and agreed to mean "licensee". Notwithstanding anything to the contrary contained herein, The COMPANY or its licensor, as the case may be, retains all rights and interest in software products provided hereunder. See the Terms & Conditions of purchase for details regarding such license.



II. Safety

IMPORTANT Safety Items to be Observed.

Safety Warnings

! DANGER (may cause serious damage to property and or casualties)

- Please carefully read this User Manual prior to operating the instrument and observe the instructions on safe operation.
- Ensure that only trained staff operate this instrument
- The power source must be grounded reliably and away from any sources of electromagnetic interference.
- Ensure that the instrument and its accessories are free of any potential defects.
- Confirm that the voltage and frequency of the power supply matches the specified voltage and frequency specified prior to use.
- Ensure the cover of the junction box is properly installed prior to operation.
- Always wear applicable PPE whilst operating the instrument.
- High Temperature Hazard; Do NOT touch the pump whilst in operation
- Avoid inhalation and contact with toxic liquids, gases, spatters, vapor, dust, biological or microbiological mediums as these may be harmful to the operator.
- Place the instrument on a stable, dry, clean, antiskid, and fireproof surface.
- Ensure there is sufficient ventilation gaps and spacing above and around the instrument
- Ensure the instrument is stable and level and will not move due to vibration upon start-up.
- The instrument must always be monitored whilst in operation.
- Gases, vapours, or other substances at the exhaust may be harmful.
- When moving the Pump ensure the Pump is switched 'OFF' and the Power Supply is disconnected.
- Ensure the lifting eye is securely tightened prior to lifting the pump.
- Ensure the pump is kept in normal operating orientation during transport. Failure to do so can cause pump damage and or oil spillage.

! WARNING (may cause property damage or personal injury)

- The working environment must be free of any flammable, explosive, volatile or corrosive substances. If long term storage is required, clean the pump and empty all oil. Store the pump in a dry clean area at room temperature
- Ensure handling and disposal of used oil and other parts are compliant with local environmental laws

and regulations.

- Do not block the motor vent.
- Only accessories listed as 'optional accessories' for use, can guarantee operational safety.
- Ensure handling and disposal of packaging is compliant to local environmental laws and regulations.

! ATTENTION (may affect operational performance or service life)

- The instrument is deenergised only when the power cable is disconnected from the power source.
- Ensure the instrument and its accessories are protected external vibration.
- The Company reserves the right to modify the design and technical data of the pump without notice.
- Only accredited and qualified professional repair technicians can open the instrument or conduct required repairs. Persons performing repairs on the instrument other than those selected or approved by the Company shall operate to void any warranty contained hereinabove for the product

2.1 After Sales Support

If problems are encountered or technical support is required when installing or using the instrument, please contact saleseurope@hollandgreenscience.com

The company may provide technical assistance and information regarding the instrument or equipment or service without charge at its sole discretion. Buyer assumes sole responsibility for any reliance on or use of such assistance and information, and the company makes no warranty thereon.

Upon contact the following information is required:

- Product serial number (located on the instrument nameplate)
- Description of issue or problem
- Method and or operating steps you have undertaken towards resolution.
- Your contact details inclusive of telephone number and email address.

III. Anemos Oil-free Scroll Vacuum Pump

3.1 Introduction

The Anemos oil-free scroll vacuum pump uses oil-free scroll compression technology. It has a low leakage rate, and a high compression ratio. The vacuum pump offers a steady pumping speed over a wide pressure range. Because the change of the compression volume is continuous, the driving torque and power are almost constant. The working cavity formed by the orbiting scroll is symmetrical and the vacuum pump has a very low level of vibrational noise. The vacuum pump is oil free, and thereby eliminates the common problem of oil contamination in the vacuum chamber.



3.2 Precautions

- The vacuum pump should not be used to remove acid or alkaline solutions or corrosive gases. Such substances will cause the pump's fixed scroll, orbiting scroll, and other parts to be corroded and shorten the lifespan of the pump. The vacuum pump can be used in applications where organic solvents need to be removed. If the pumping medium contains water vapor or liquid water, it may adversely affect the pump's throughput and lengthen the time needed to attain an acceptable level of vacuum.
- The vacuum pump uses PTFE material for the tip seal on the compression chamber. It is normal for a small amount of PTFE powder to be present in the exhaust during pumping. Therefore, it is strongly recommended that no exhaust silencer or muffling system be used at the pump's outlet. If a filter-type silencer must be installed due to noise, it is recommended that the filter be cleaned regularly and replaced every six months. The silencer may cause the exhaust pressure of the pump to rise due to the air resistance and shorten the lifespan of the pump.
- The vacuum pump is not suitable for removing substance that contains a large amount of powder. The composition, size, and content of the powder will affect how well the pump works. Please contact the service department first before purchasing to confirm that the vacuum pump is suitable for your application if a large amount of powder needs to be pumped.
- If the pump has been unused for more than 3 days, or the customer needs to pump the chamber to below 5 Pa, it is recommended that the pump be first run for 20 minutes with no loading (open the air inlet first and vent for 1-2 minutes).
- If a small amount of liquid water or water vapor gets into the pump, it will affect the pumping rate and increase the amount of time to achieve vacuum. It is recommended that the pump run with the gas ballast open for about 20 minutes to remove any water from the pump.
- The vacuum pump should not be operated with an open inlet port for any significant time.

IV. Technical Specifications

4.1 Specifications

Model		21111008
Product Name		Anemos
Nominal pumping speed	L/S	3
	L/min	180
Ultimate Vacuum	mbar	0.008
	Pa	0.8
Leak rate	mbarl/s	$< 1 \times 10^{-6}$
	pa·m ³ /s	$< 1 \times 10^{-7}$
Motor voltage (V)		Single-phase 230V/50Hz
Motor power (W)		400
Motor speed (rpm)		1800
Max Current Draw (Amps)		3
Dimension (mm)		430 L x 255 W x 290 H
Noise (dB(A))		54
Inlet port		NW 25
Outlet port		NW 25
Water vapor capacity (gh-1)		100
Weight (kg)		28
Cooling		Air
Ambient Temperature (°C)		5 - 40

4.2 Dimensions

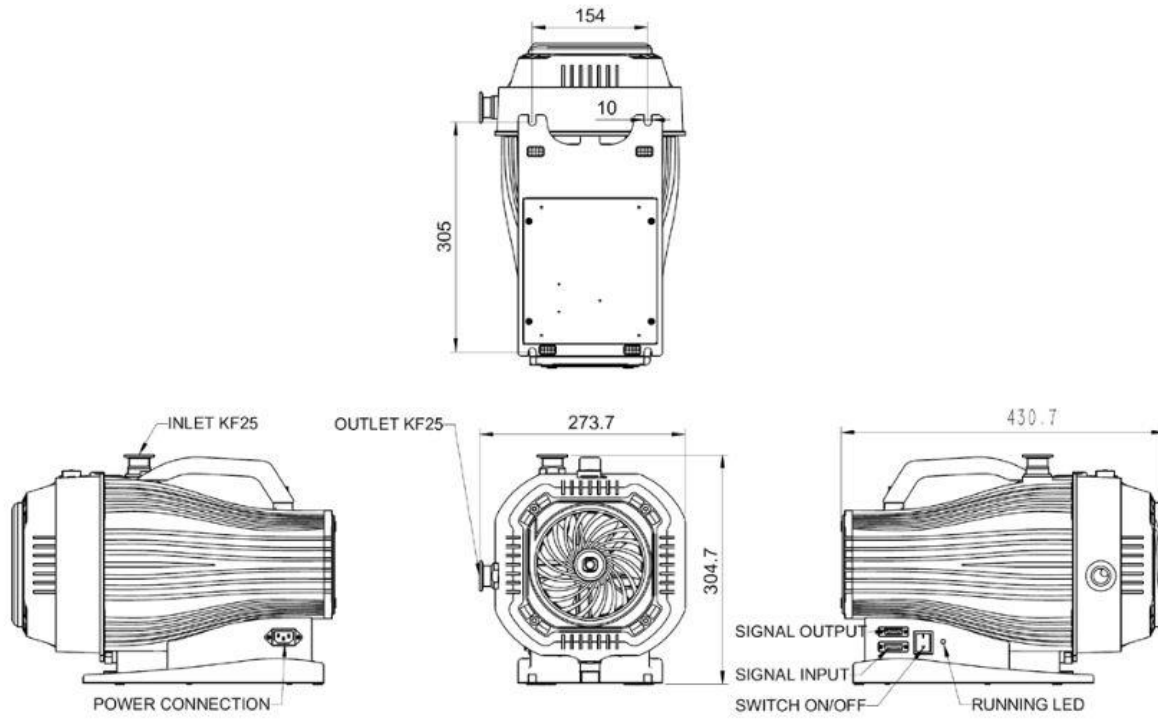

V. Installation and Operation

5.1 Operation environment requirement

- Do not expose the pump to wet conditions (such as rain or steam). Moisture may cause the power connector to malfunction.
- Do not expose the pump to flammable or explosive gases.
- The pump should be operated in a temperature controlled environment from ° 5 C to 40 ° C. If operated outside this temperature range, the pump may be damaged.
- The pump should not be used in a dusty environment or near corrosive gases. Operating in such environments will reduce the lifespan of the pump.
- There should be adequate ventilation for the pump.

5.2 Electrical Connection

The Anemos vacuum pump uses a single-phase power. Wiring method is shown below.

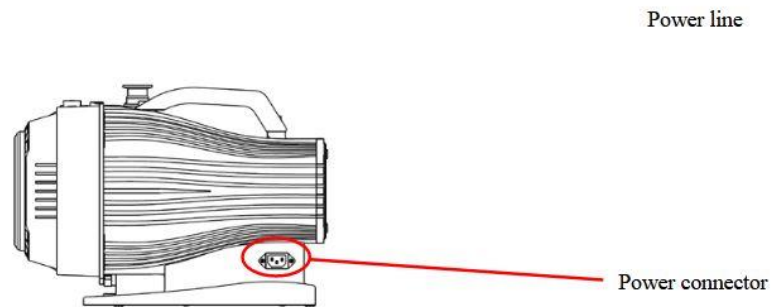

Connect the power line to the power connector on the pump. Turn on the power switch (“1” is pressed and “0” is in the raised state) and the pump is ready to run.

5.3 Operation

- Before starting be certain that all sure seals are tightly secured.
- If the pump is used for the first time or used after a long period of inactivity, open the inlet and outlet ports and run the pump for 5 minutes to remove any water vapor that might get into the compression chamber.
- Close the isolation valve between the pump and chamber to prevent blow-back.

VI. Interface

There are two 15-pin female serial ports located on the base of the pump. The top 15-pin serial port doesn't apply to this vacuum pump model. The bottom 15-pin serial port is used to connect a pressure sensor to the vacuum pump to read pressure data.

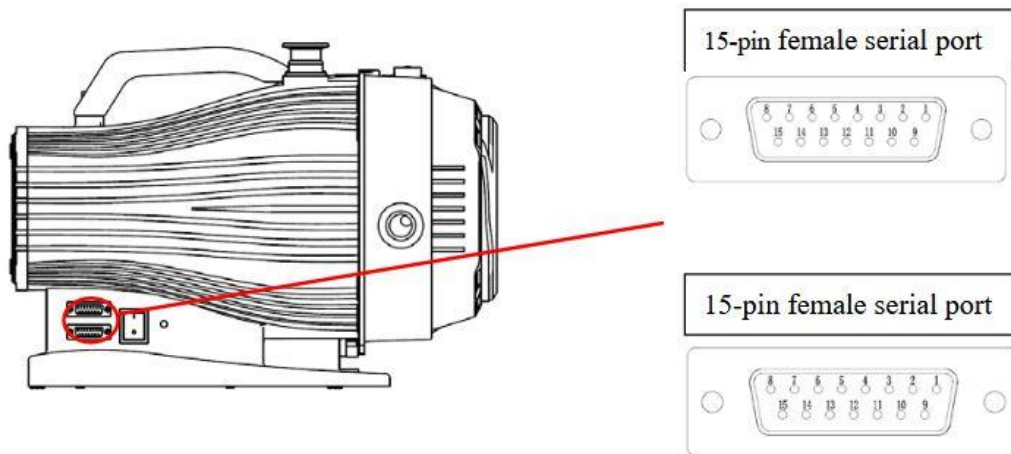

6.1 Pin definition

The bottom 15-pin female serial port (pressure sensor port)

No	Signal	Function
1	A+	Serial communication 485A +
2	B+	Serial communication 485B+
9	485SG	Serial communication 485 ground
7	24V	Pressure sensor 24V power
8	FIC	Pressure signal 1-5V/0-10V
15	GND	Pressure sensor 24V power ground

VII. Inspection

Unpack the equipment carefully and check for any damage which may have arisen during transport. In the event of identified damage, please contact saleseurope@hollandgreenscience.com

The package includes the following items

Item Description	Quantity
Main Unit	1
Quick Setup Card	1
Plastic cover	2
Power cable	1
NW25 Net filter (Including O-ring)	1
Inspection certificate	1

	<p>CAUTION:</p> <p>If there is any visible damage to the instrument, please do not connect the instrument to a power supply.</p>	
---	---	--

VIII. Maintenance

When the pump is used for a specified period, some inspection and maintenance work is required. Otherwise, it will affect the performance and lifespan of the pump.

Inspection part	Maintenance frequency	Remark
	Two years or 12000 hours	
Bearing	○	
O-ring	○	
Tip seal	○	

- – Replace

Maintenance work should be done by the manufacturer or authorized distributor. Disassembling the pump beyond the above stated bearing, O-ring, tip seal replacement by the customer will void the warranty.

IX. Troubleshooting

Fault	Possible Reason	Remedy
Pump Not Starting	Power supply protection component malfunction	Check if the protection component is normal.
	Loose or broken wires	Check for bad contact and repair, replace the problematic wire.
	Motor overload or open circuit	Return to the service department for repairing.
	Defect pump	Return to the service department for repairing.
Poor ultimate vacuum	A leak in the system	Leak testing
	Damage of the O-ring	Replace the O-ring
	Water vapor inside the pump	Install a filter to prevent water vapor. Open the inlet port to ATM for several minutes. Run pump with gas ballast for about 24 hours.
	Gas ballast block	Adjusting the pressure balance
Abnormal noise and vibration	Connection loose	Make connection tight
	The installation location is not horizontal	Make the pump installed horizontally
	Dust into the pump body	Return to the service department for repairing
	Exhaust port defect	Return to the service department for repairing
	Motor defect	Return to the service department for repairing
	Defect pump	Return to the service department for repairing

Holland Green Science Europe B.V.

Mauritskazerne D41, Office D21

Nieuwe Kazernelaan 2

6711 JC EDE, The Netherlands

Tel: +31643498156

E-mail: SalesEurope@hollandgreenscience.com

E-mail: ServiceEurope@hollandgreenscience.com

Chamber of Commerce number: 82526494

VAT number: NL862505744B01